

Instruction Sheet

Subject: 8263510 Basket Lift Installation Instructions (Electric)

Models affected: RE Electric Fryers

Follow these instructions to install the basket lift kit.

1. Disconnect power from the fryer.
2. Remove the fryer from the hood to gain access to the rear of the fryer.
3. On the rear of the fryer, remove the 4 side screws towards the outer edge of the fryer (see Figure 1).
4. Using the screws removed from previous step, insert the screws into the holes in the center of the fryer back (see Figure 2) and thread the holes, if not already threaded.

Remove the screws after threading.

5. Using the screws removed from step 3 and supplied screws, attach the basket lift assembly (see Figure 3). If any of the holes don't line up, use the supplied self-tapping screws.



Figure 1



Figure 2



Figure 3



Figure 4

6. Insert the supplied cable assembly through the opening in the bottom of the basket lift assembly. Connect the male Molex connector to the female Molex connector (see Figure 4).

7. Attach the conduit plate to the bottom of the basket lift assembly using 4 supplied screws (see Figure 5).



Figure 5

In This Kit		
Part #	Description	Qty
1085033	BASKETLIFT ASSY FPRE14/17/22	1
8238465	ARM W/A RE MODULAR BL LEFT	1
8238466	ARM W/A RE MODULAR BL RIGHT	1
1087489	CABLE ASSY RE	1
8090364	SCREW, #8 X 5/8" HX	14
8090361	SCREW, DRILL #8 X 1/2" HX	6
8091101	SCREW, #12X1/2 HX	3
8074056	CONNECTOR, 3 WIRE SNAP	2
8140015	TY WRAP	6
2309618	GUIDE, BASKET LIFT FM/FPRE ARM	1
2601474	COVER, BASKET LIFT HANGER	2
8090047	NUT, CAP 1/4"-20	4
8197543	INSTRUCTIONS	1

8. Route the other end of the conduit harness to the front of the fryer (see Figure 6).
9. Remove the bezel (see Figure 7).
10. Remove the two screws, attaching the controller, associated with the basket lift (see Figure 8).



Figure 6



Figure 7



Figure 8

11. With the controller folded down, unplug the harnesses and remove the controller (see Figure 9).
12. Remove the lower panel to gain access to the lower control box (see Figures 10 and 11).

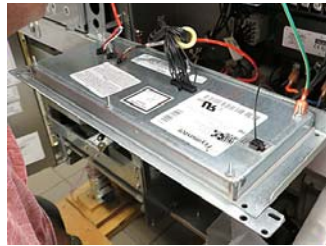

Figure 9



Figure 10



Figure 11

13. Locate an unused opening in the lower rear of the control box and knock out the grommet (see Figure 12).

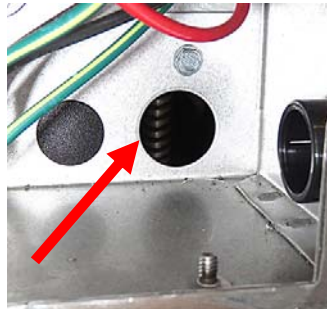

Figure 12

14. Remove the conduit nut from the fitting on the conduit (see Figure 13).



Figure 13

15. Insert the wires and conduit into the opening and the nut. Secure the conduit using the conduit nut (see Figure 14).

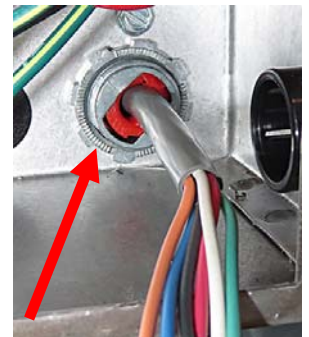

Figure 14

16. Use the wiring diagram on the last page to assist in the following steps.
17. Remove the 12-pin J1 plug from the bottom left of the interface board (see Figure 15).
18. Insert the red wire into the J1 plug pin 7 (see Figure 16). (**Note** – Pin 1 is indicated by the ridge in the corner (see Figure 17 and 18)).

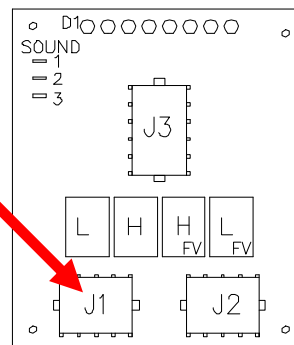

Figure 15

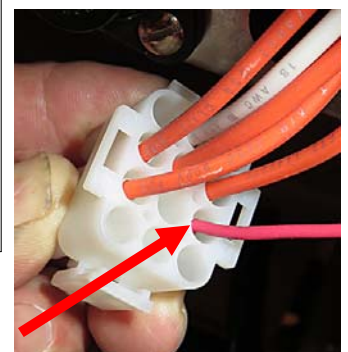

Figure 16

19. Plug the connector into J1 socket on the interface board.



Figure 17

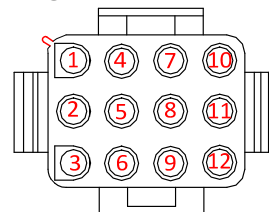

Figure 18
Viewed from the Rear

20. Remove the 12-pin J2 plug from the bottom right of the interface board (see Figure 19).
21. Insert the blue wire into J2 plug pin 4 (see Figure 20).
22. Insert the orange wire into J2 plug pin 5 (see Figure 21).
23. Remove the left black line voltage piggyback connector to the transformer (see Figure 22).
24. Attach a supplied piggyback connector to the connector removed in the previous step. Connect the black wire, from the new basketlift harness, to the added piggyback and reattach to the transformer (see Figure 23).

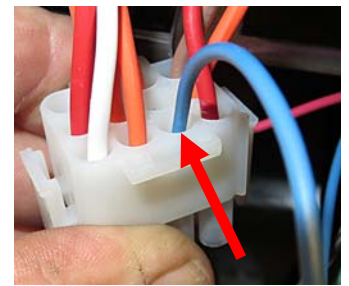
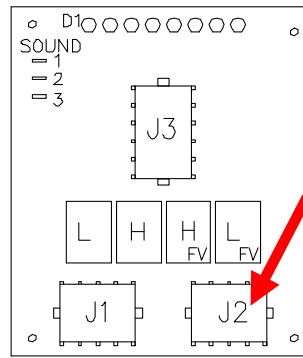

Figure 20

25. Repeat steps 24 and 25 for the right line voltage piggyback connector, connected to the transformer, to attach the white wire from the harness, to the transformer (see Figure 23).

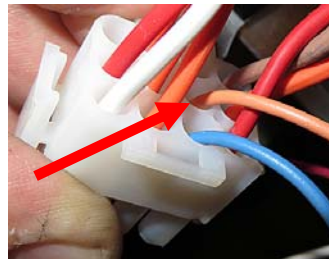

Figure 21



Figure 22



Figure 23

26. Attach the green ground wire from the harness to an existing ground screw in the box (see Figure 25).
27. Use ty wraps to secure wires.
28. Reattach the lower plate (see Figure 26).
29. Reattach the controller and bezel removed in steps 9 and 10.
30. Reconnect power to the fryer.



Figure 24



Figure 25



Figure 26

31. Enable basketlift in vat setup of RE fryers. See IO manual for instructions.
32. Turn on fryer and test both sides of the basketlift, ensuring that both arms raise and lower when starting a cook, associated with the basketlift side.
33. Attach the included wiring diagram to the inside of the basketlift cover (see Figure 27).
34. Slide the cover over the basket lift arms (see Figure 28).
35. Attach 3 cabinet screws to the two outer holes and the center hole, on the top of the basketlift cover (see Figure 29).



Figure 27



Figure 28



Figure 29

34. Slide the cover over the basket lift arms (see Figure 28).
35. Attach 3 cabinet screws to the two outer holes and the center hole, on the top of the basketlift cover (see Figure 29).

36. Using supplied 8091101 screws, attach to the cover using the two inner holes (see Figure 30).
37. Remove existing basket lift hanger (see Figure 31) and discard.
38. Slide new basket lift bracket over the existing studs (see Figure 32).
39. Attach the new arms into bracket by inserting at a 45 degree angle and placing over the basket lift shaft (see Figures 33 and 34).
40. Insert the baskets into the basket lift arms.
41. Ensure the fryer is repositioned under the hood.
42. Use enclosed Wago snap wire connectors, if necessary, to splice into the wires.



Figure 30

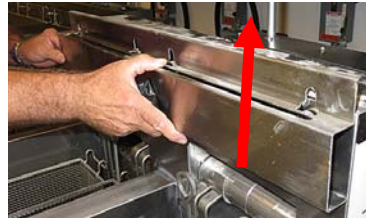

Figure 31

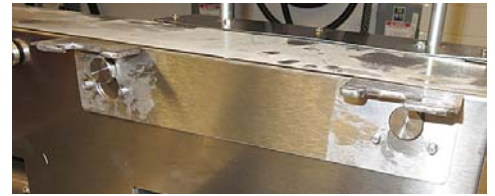

Figure 32



Figure 33



Figure 34



Figure 35

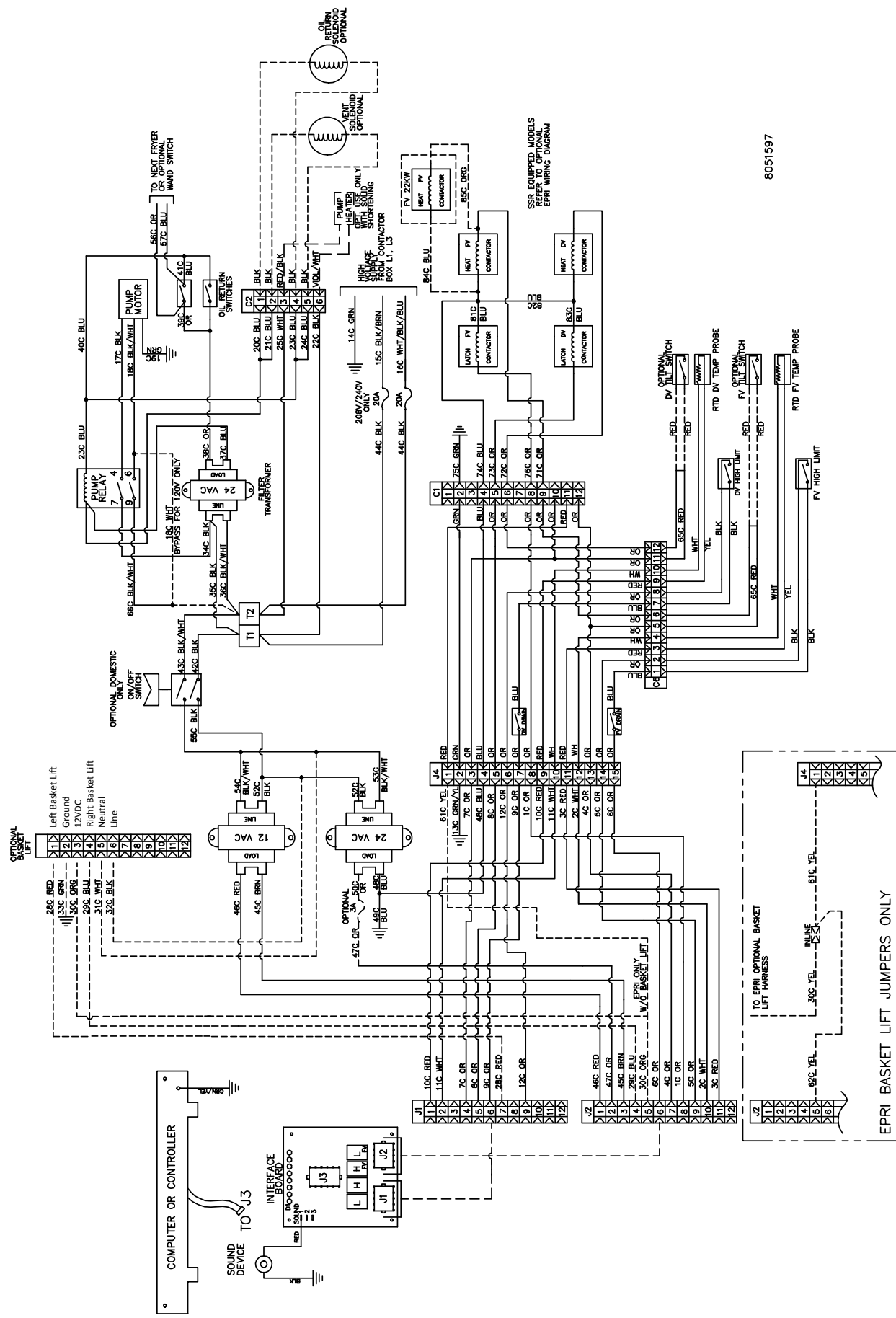

80051597

800 EQUIPPED MODELS REFER TO OPTIONAL EPRI WIRING DIAGRAM

EPRI BASKET LIFT JUMPERS ONLY